

SAP's Learning Solution

- General Overview

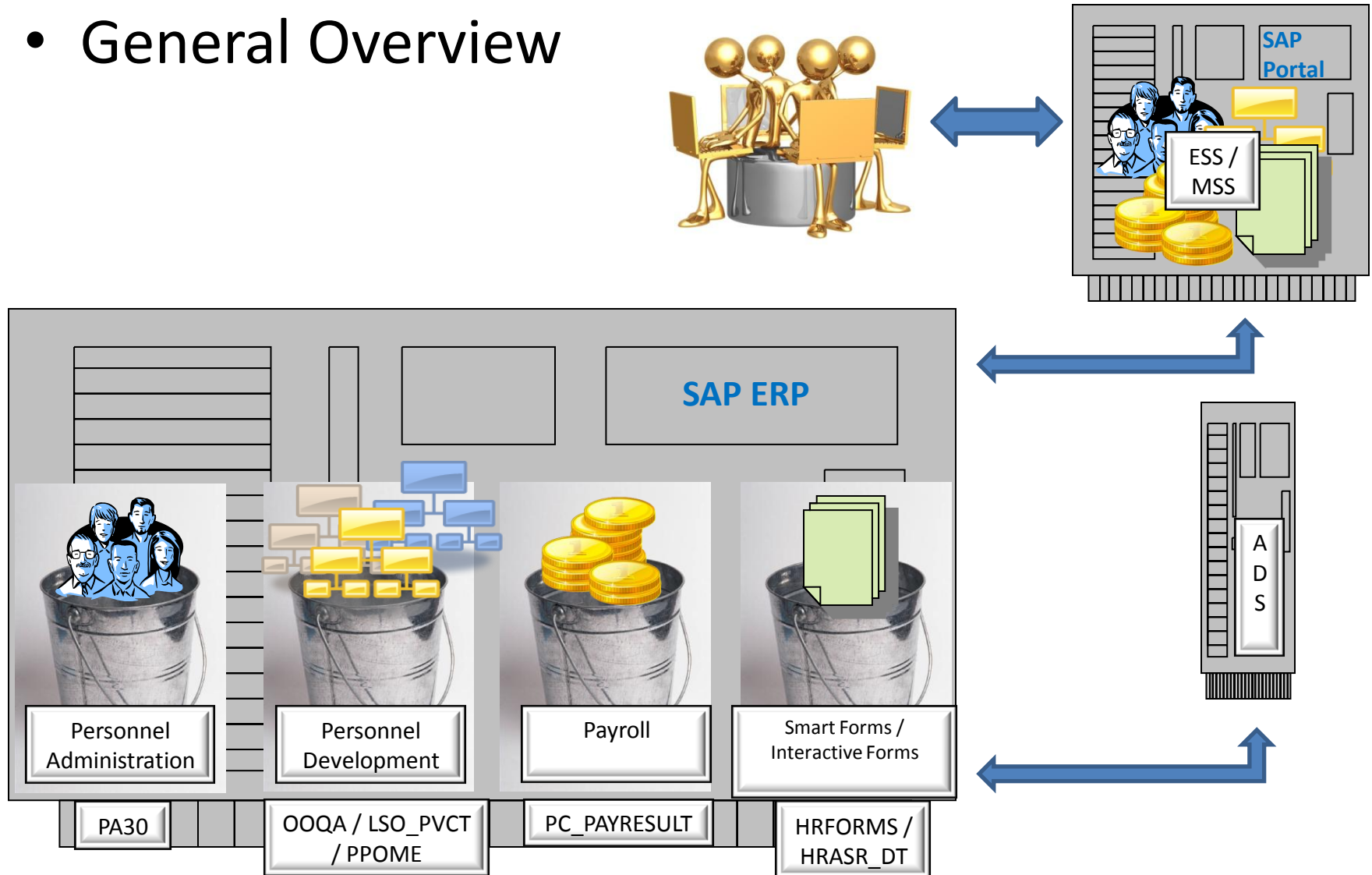

- The SAP Personnel Development Model

SAP's Learning Solution

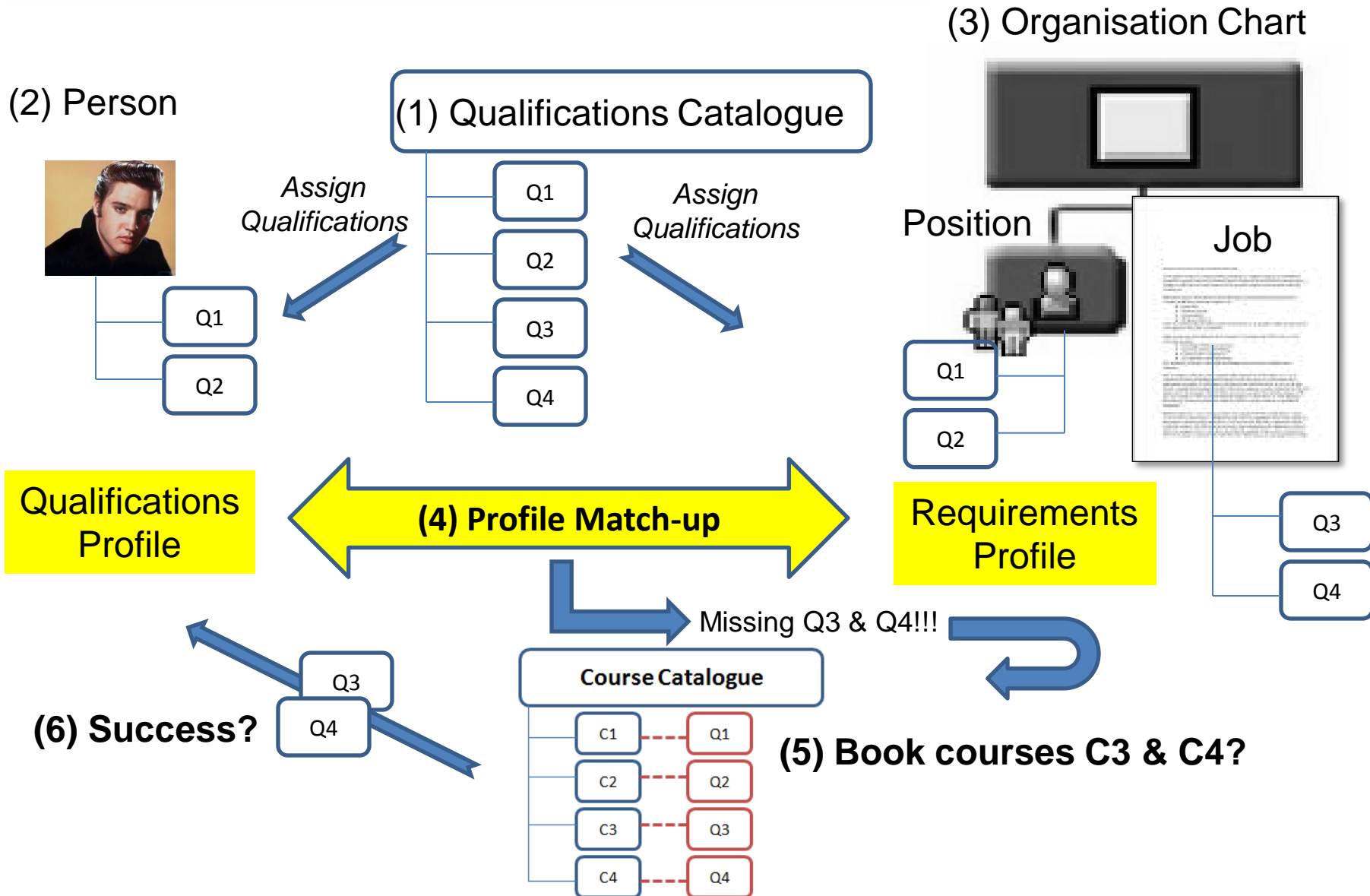

SAP's Learning Solution

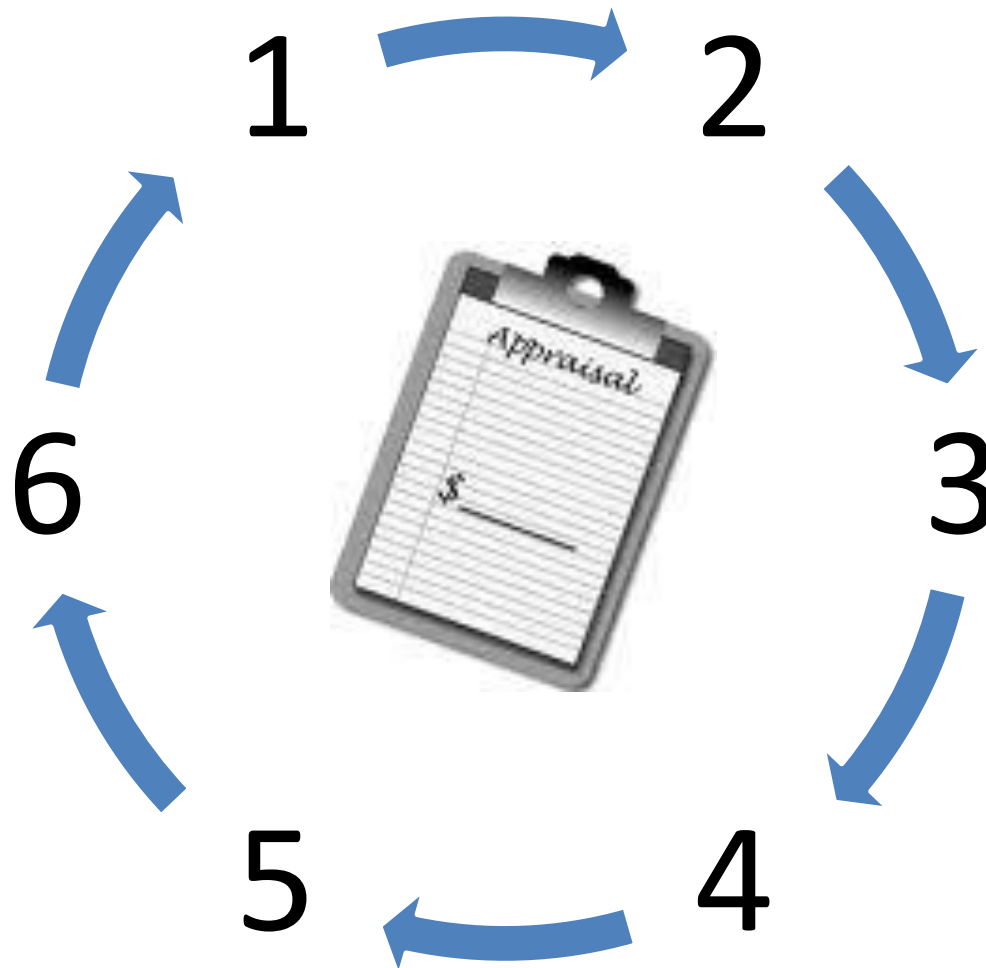

SAP's Learning Solution

Organisation Chart

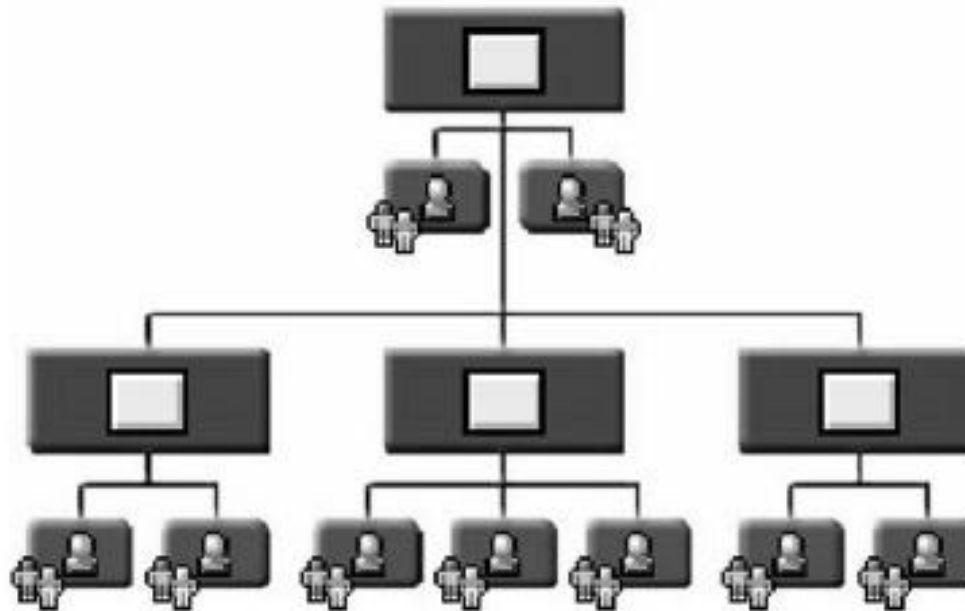

SAP's Learning Solution

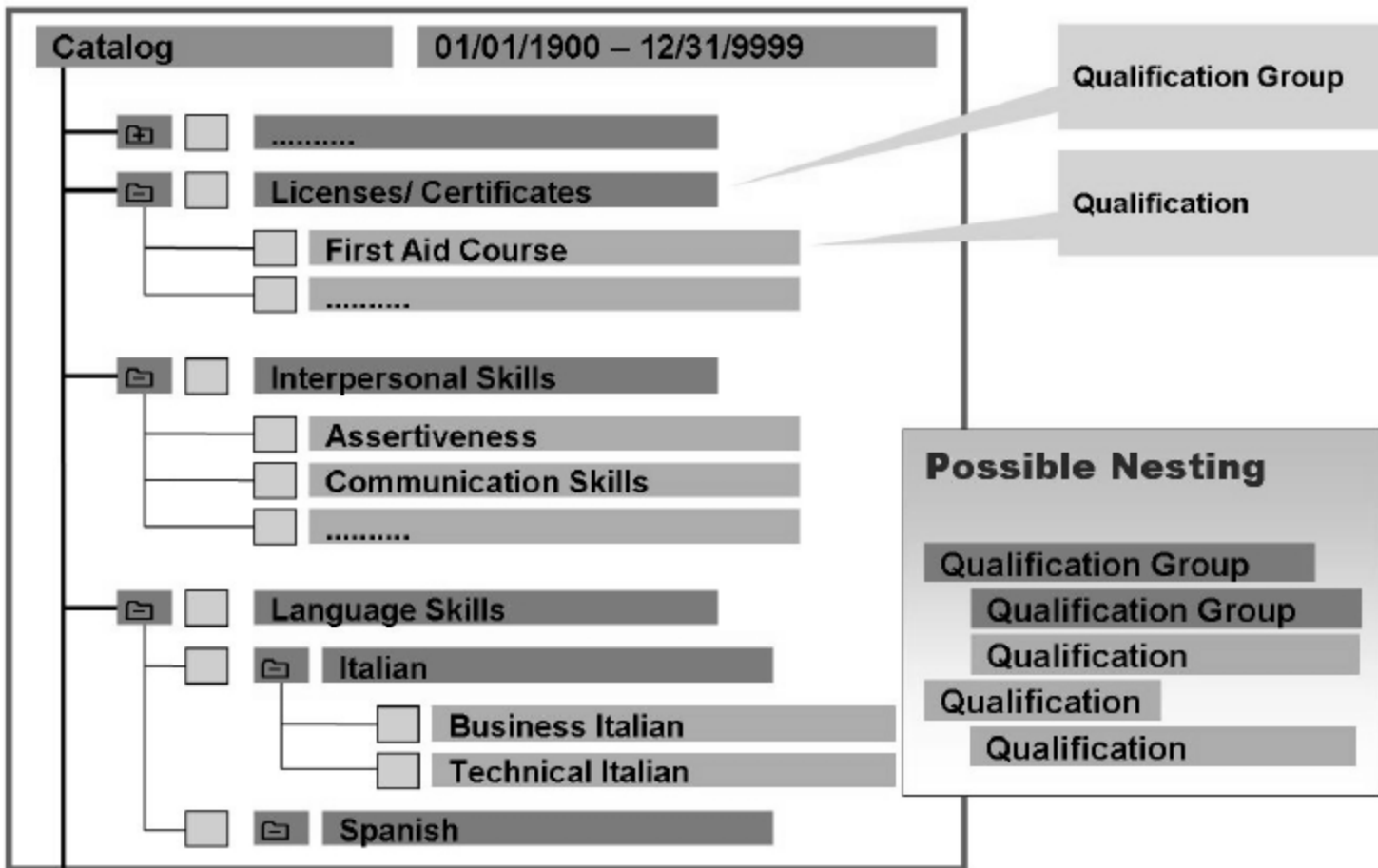

Figure 40: Structure of the Qualifications Catalog

SAP's Learning Solution

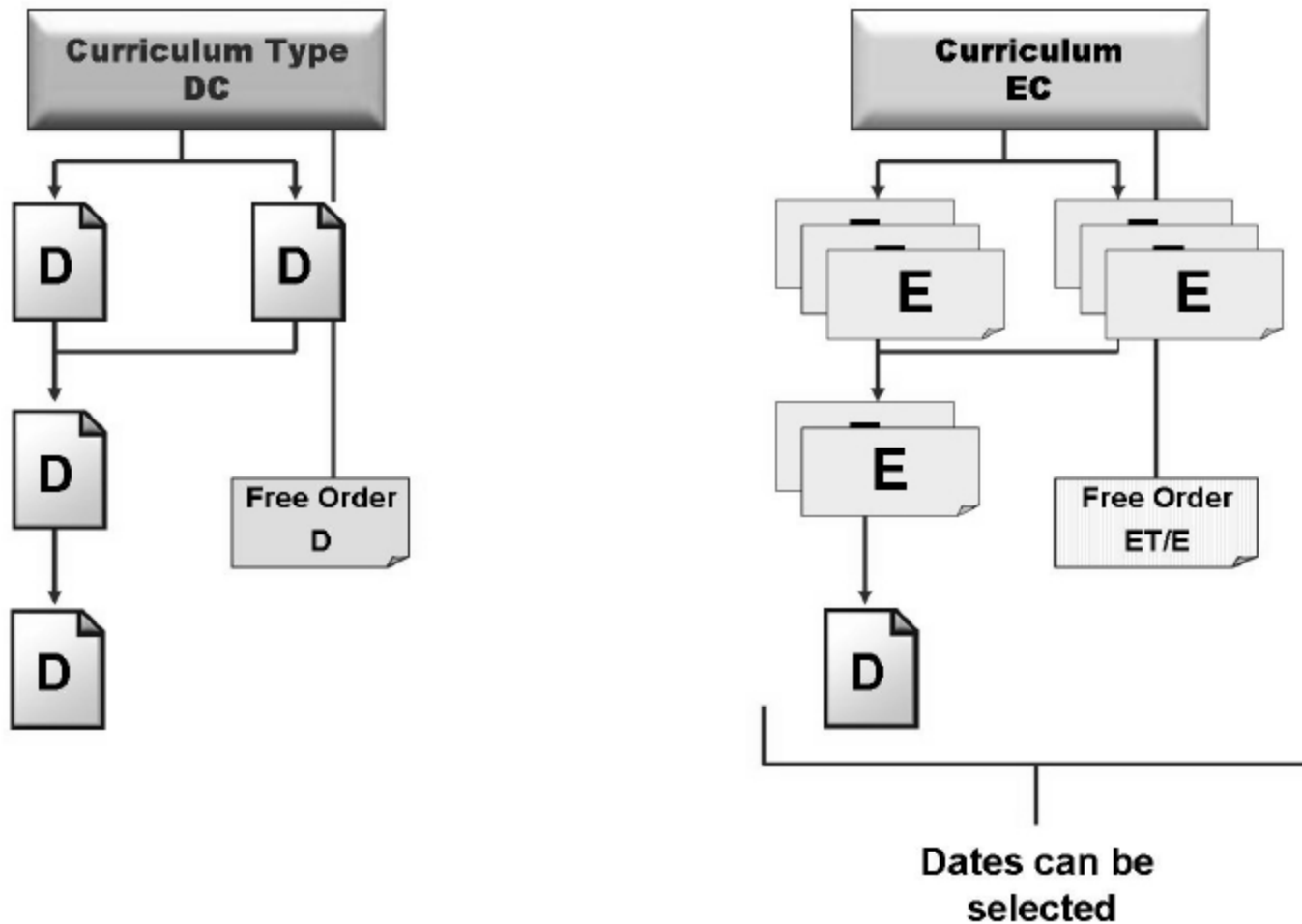
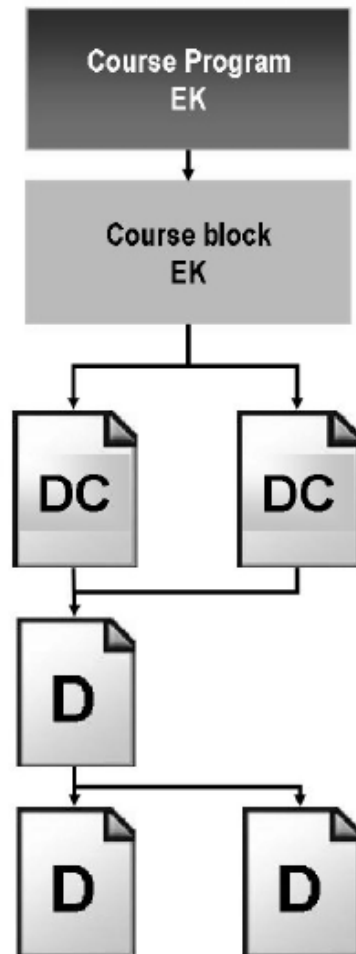

Figure 58: Data Model for New Object Types

SAP's Learning Solution



Course types and curriculum types are assigned to the course program, and divided into course blocks. Course blocks are also from the object type EK.

Blocks and course types within the blocks can also be assigned sequence rules.

Alternatives can be defined for course types and curriculum types.

Figure 61: Example of a Data Model for a Course Program

The Learning Solution

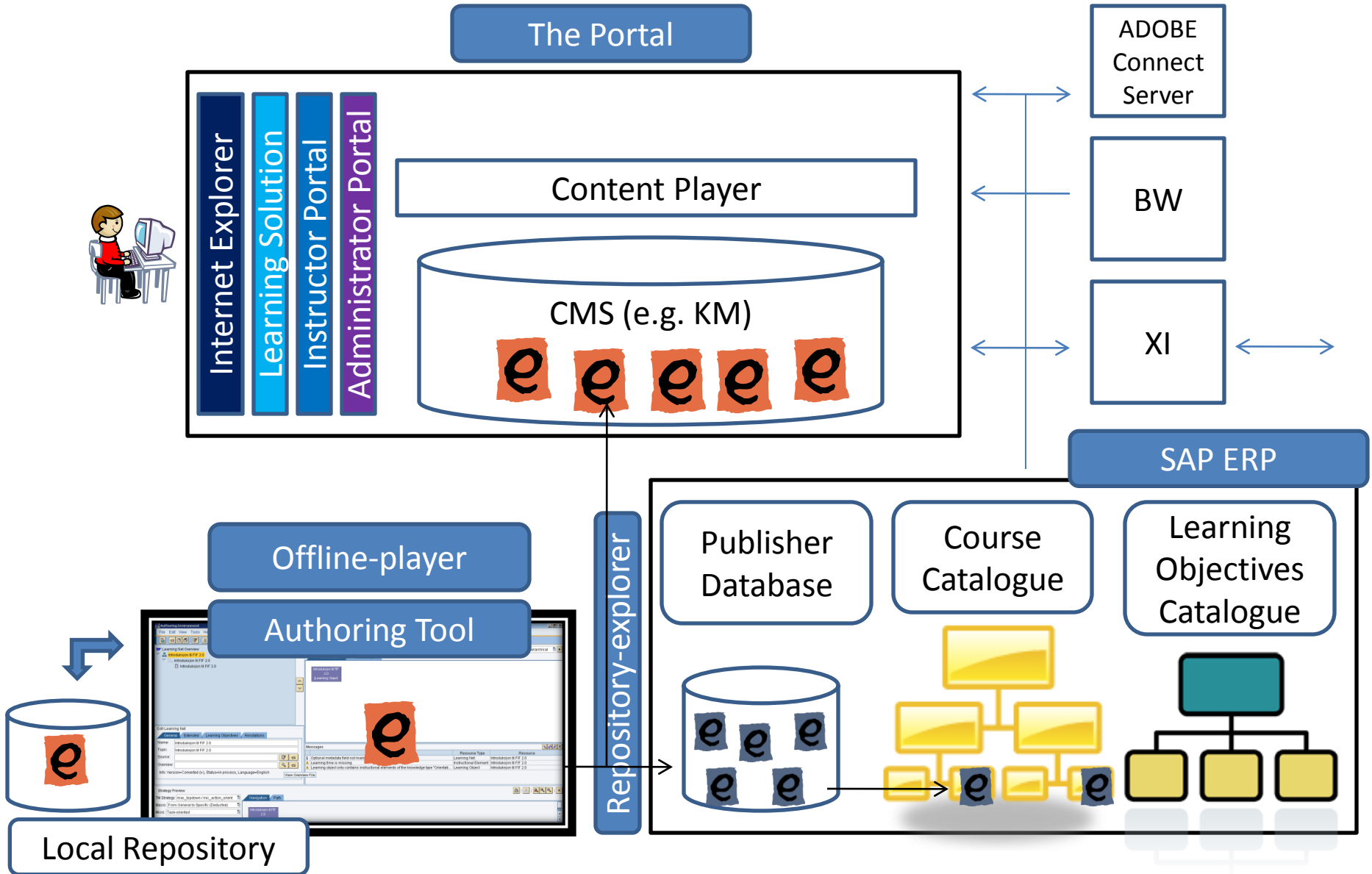

The Authoring Tool

The screenshot displays the 'Authoring Environment' software interface. The title bar indicates it is running on a Citrix online plug-in. The main window is divided into several sections:

- Learning Net Overview:** A tree view on the left showing the project structure. The 'Work Area' is currently selected.
- Work Space:** A central diagram showing the relationships between components. 'Objects Panel [Overview, Image]' is at the top, with two 'Before' labels below it. Arrows point from the 'Before' labels to 'Status Bar [Overview, Image]' and 'Work Area [Overview, Image]'. A red arrow also points from 'Work Area' to 'Objects Panel'.
- Edit Learning Object:** A panel on the left with tabs for 'General', 'Extended', 'Learning Objectives', and 'Annotations'. The 'Name' field contains 'Work Area'. The 'Info' field contains 'Version=Work_Area (v1), Status=Released for reuse, Language=English'.
- Messages:** A table at the bottom right listing various messages and their associated resources.
- Strategy Preview:** A section at the bottom showing a navigation path: 'Work Area [Overview, Image]' → 'Objects Panel [Overview, Image]' → 'Status Bar [Overview, Image]'.

	Short Description	Resource Type	Resource
⚠	Learning time is missing	Instructional Element	Welcome Module 1
⚠	Learning time is missing	Instructional Element	End Module 1
⚠	Topic is missing	Learning Net	Basics
i	Optional metadata field not maintained	Learning Net	Basics
⚠	Learning time is missing	Instructional Element	Work Area
⚠	Learning time is missing	Instructional Element	Objects Panel

SAP & SCORM Terms

A Book	SAP	SCORM Shareable Content Object Reference Model
Collection of Training Manuals	Learning Nets	Content
Training Manual	Learning Net	Block
Chapter	Learning Object	SCO (Shareable Content Object)
Lesson	Instructional Element	---
Page	Media Resource	Asset

Learning Strategies

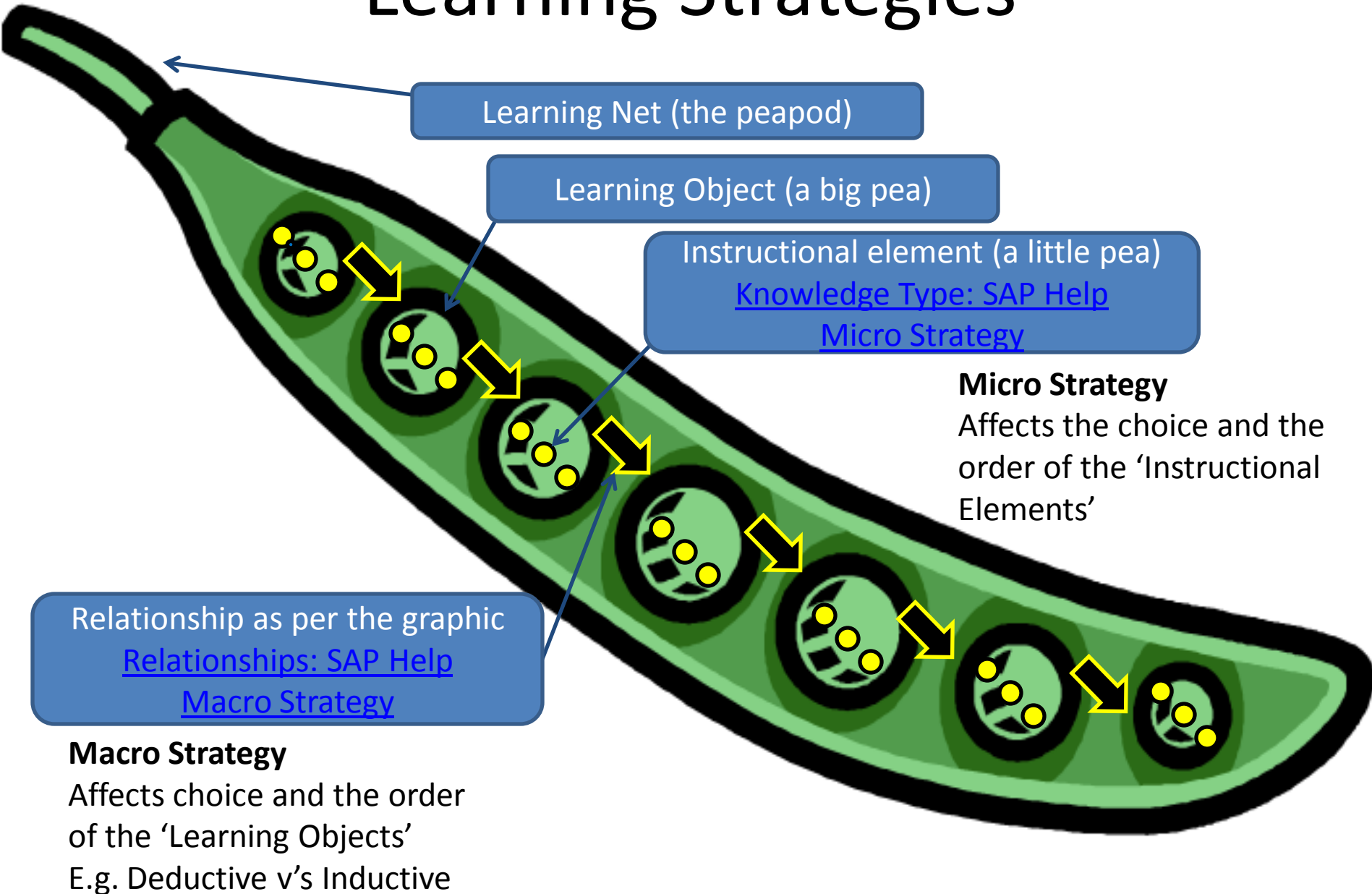

Learning Strategies

Macro Strategy

- If no relationships exist between 'Learning Objects' or just the 'Before' relationship then the course will not change depending on the Learning Strategy.
- Main Examples
- **Deductive:** Top / Down i.e. General to Specific
- **Inductive:** Bottom /Up i.e. Specific to General

Relationships Between Learning Objects

<i>Hierarchical</i>	<i>References</i>	<i>Alternative</i>	<i>Didactic Relationships</i>
Consists of	Determines		Belongs to
Generalizes	Context of		Before
	Means of		Prerequisite of

Learning Strategies

Micro Strategy

The following micro strategies are used in the *Content Player*:

- *Orientation only*

Only the orientation knowledge of the [learning objects](#) is displayed. No other [knowledge types](#) are displayed.

- *Initial orientation*

Orientation knowledge is displayed to start with and then the other knowledge types.

- *Explanation-oriented*

Explanatory knowledge is displayed to start with and then the other knowledge types.

- *Task-oriented*

Practical instruction is displayed to start with and then the other knowledge types.

- *Example-oriented*

Example knowledge is displayed to start with and then the other knowledge types.

- *Table of contents*

This strategy simply uses the table of contents, ignoring knowledge types and relationships.

- SCORM v1.2 and SCORM 2004 (v1.3)

These are the micro strategies used with the corresponding SCORM macro strategies. You use these strategies for learning nets from external learning management systems that are imported as SCORM courses.

- AICC

This is the micro strategy used with the corresponding AICC macro strategy. You use this strategy for learning nets from external learning management systems that are imported as AICC courses.

Completion Progress: SAP ERP

The screenshot shows the SAP ERP 'Display Completion Specifications' dialog box. The interface includes a menu bar (Infotype, Edit, Goto, View, System, Help), a toolbar with various icons, and a search pane on the left. The main area contains fields for Course Type (BlackBerry), Planning Status (Active), and Start date (01.01.2004 to 31.12.9999). Below these are sections for Completion Specifications and Follow-Up Options.

Completion Specifications		
Maximum Completion Time	50	MIN
Minimum Completion Time	20	MIN
Optimum Completion Time	35	MIN
Specified License Period	0	DAY
Availability End Date		
Allowed No. of Accesses	0	
Participant Cancellation	Always cancel courses	

Follow-Up Options	
<input type="checkbox"/> Include Achieved Learning Objectives as Success Criteria	
% Learning Objectives to Be Achieved	0.00
<input checked="" type="checkbox"/> Include Completed Learning Objects as Success Criterion	
% Learning Objects to Be Completed	80.00

Completed Learning Objectives:
Total number of learning objectives completed / total number in Learning Net

Completed Learning Objects:
Total number of learning objects completed / total number in Learning Net

Completion Progress: The Portal

Web-Based Training : BlackBerry :

[Course Catalog](#) > [Professional Training](#) > [Information systems](#) > [Handheld Tools](#) > BlackBerry

You are already booked for this course.

[Start Course Now](#)

Course Duration

The average completion time for this course is 35 Minutes (minimum 20 Minutes, maximum 50 Minutes). The course is licensed from 10.04.2010 to 31.12.9999.

Completion Progress:
Total number of instructional elements completed / total number in Learning Net

Completed Learning Objects:
Total number of learning objects completed / total number in Learning Net

Learning Progress

Booking Date	10.04.2010
Course is licensed as of	10.04.2010
First Accessed on	Not Yet Started
Last Accessed on	Not Yet Started
Total Completion Time to Date	0 Minutes
Completed Learning Objects	0%
Completion Progress	0%
Current Status	0%
Completion Status	The course has

Current Status:
Total number of learning objects TO BE completed / total number required to be completed

Check In

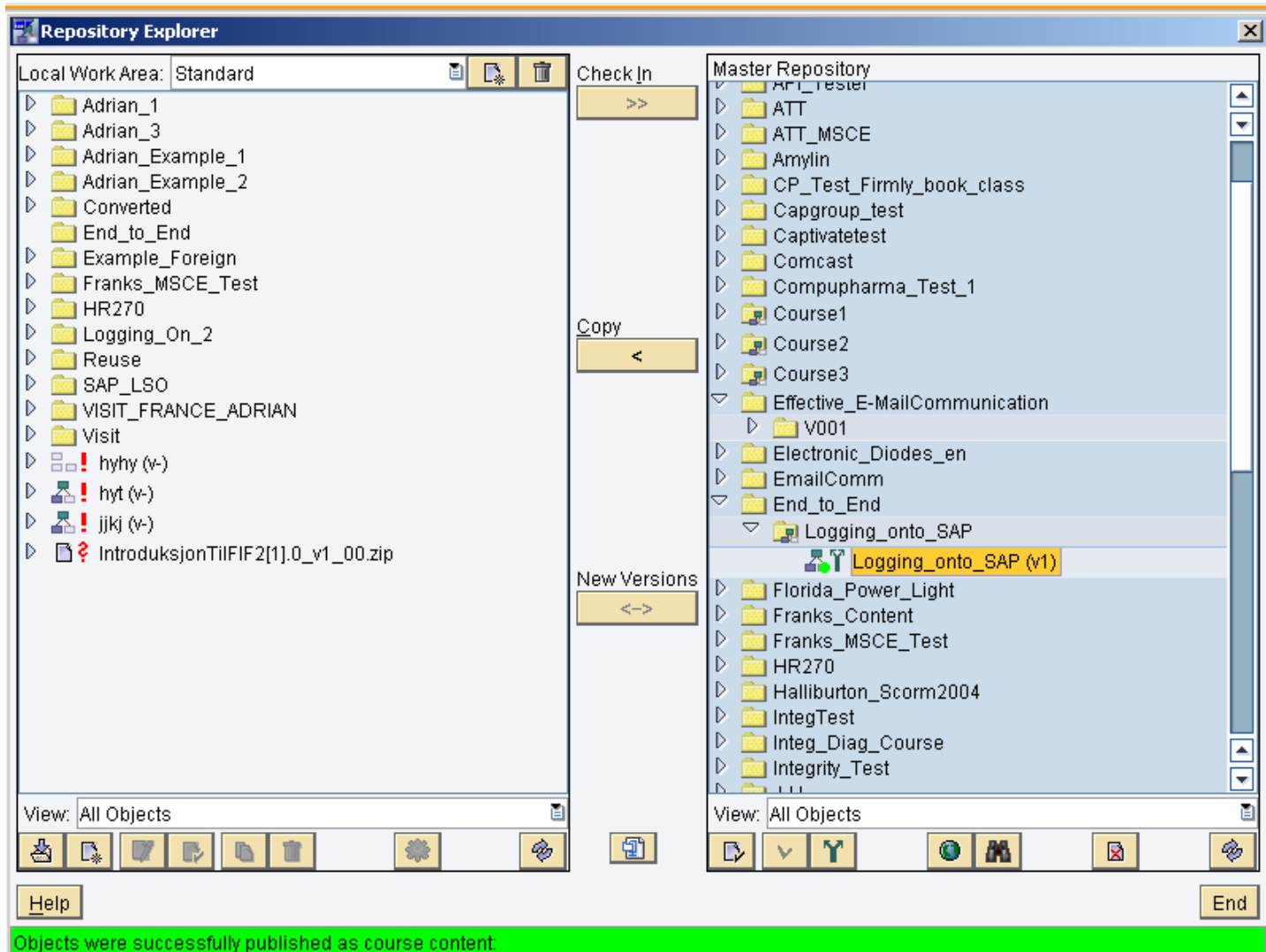

Portal

The screenshot displays the SAP Learning Solution portal interface. The browser window title is "SAP Learning Solution - Windows Internet Explorer". The page is titled "Web-Based Training : Logging on to SAP" and shows a successful login confirmation: "Participation was successfully completed". A "Start Course Now" button is visible. The course details include "Course Duration" (average completion time), "Fee" (Free of Charge), and "Learning Progress" (Booking Date, Course is licensed as of, First Accessed on, Last Accessed on, Total Completion Time to Date, Completed Learning Objects, Completion Progress, Current Status, Completion Status). A "Confirm Participation" button is at the bottom of the details section.

The main content area features a simulation titled "Logging onto SAP" with options for "Auto Playback Tutorial" and "Self Test Tutorial". The simulation includes the RWD uPerform logo. Below the simulation, the following details are provided:

- Description:** Logging onto SAP
- Created by:** Anon000
- Date Published:** Saturday, April 10, 2010
- Copyright:**

A note at the bottom of the simulation area states: "If you are experiencing difficulties viewing this simulation, please open the [Adobe Flash Player Global Security Settings Panel](#) and select the **Always allow** option."

Navigation and search options are available on the left side of the page:

- Navigation:** Training Home, Information
- Find:** Search Term , Find, Extended Search
- Course Catalog:** Business Management & Leadership, LSO600 EHP2, Core Employee Development, Environmental Training, HR270 Basic Group, JH Group, Languages, Management and Leadership Development, Professional Training, SAP Technology Training, Personal Development with SAP HCM
- My Learner Account:** Training Activities, Course Prebookings, Favorites, Qualifications Profile, Profile Matchup, Settings

At the bottom right of the page, there are buttons for Settings, Print, Help, and Log off.

Creating a Learning Net from a SCORM Course: Convert

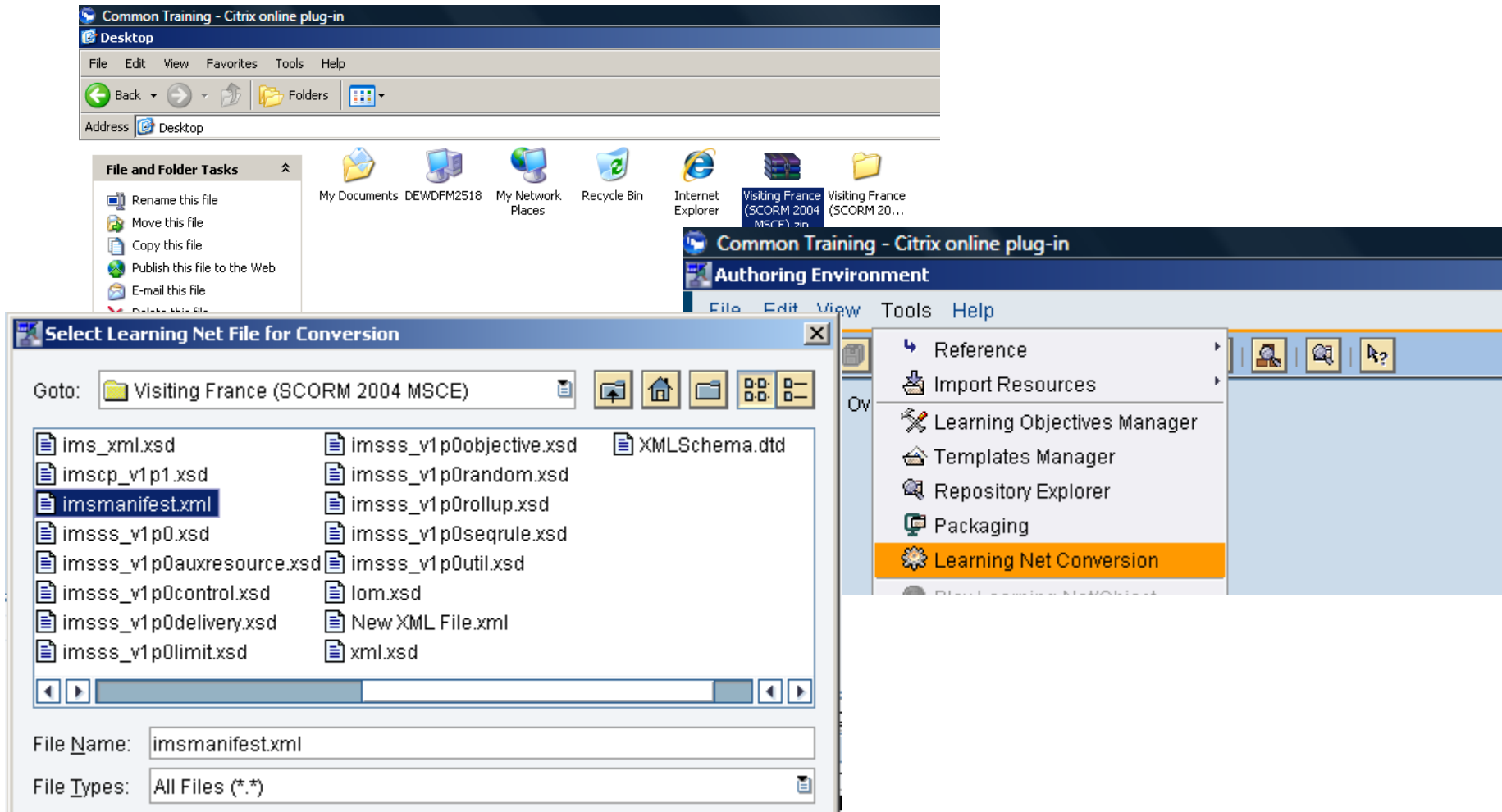

Creating a Learning Net from RWD Course: Import

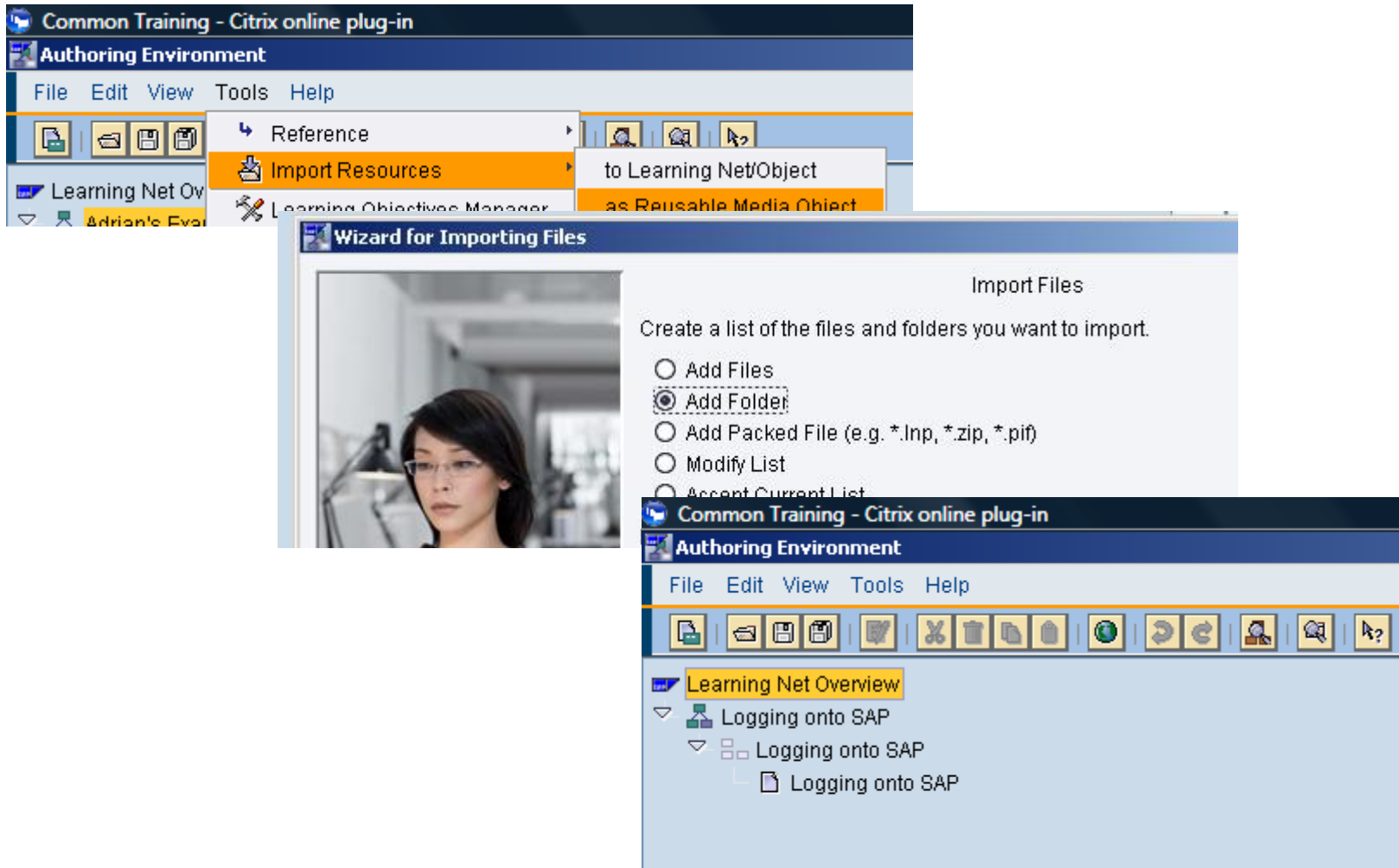

Other Reporting: SAP ERP

Statistics for Test Items: Online_Test

Test Item Statistics : Online_Test



SelectionPeriod 01.01.1900 - 31.12.9999



Test	Numb...	Max. Score	Item Total	Mean Value...	Mean V...
▼ Online_Test				71.00	5.00
▼ Section				0.00	0.00
▼ Item Group				71.00	5.00
Question 1	1	1		0.00	0.00
Question 2	1	1	1	100.00	1.00
Question 3	1	1	1	100.00	1.00
Question 4	1	1	1	100.00	1.00
Question 5	1	1		0.00	0.00
Question 6	1	1	1	100.00	1.00
Question 7	1	1	1	100.00	1.00

Other Reporting: Questionmark

<http://www.questionmark.com/uk/perception/index.aspx>



HOME PRODUCTS & SERVICES DOWNLOAD TRY IT OUT CUSTOMERS SUPPORT COMMUNITIES LEARNING ABOUT

SEARCH

>> Advanced search

SITE OPTIONS

- >> Print this page
- >> E-mail this page
- >> Newsletter sign-up

★ Add to Learning List

Join us for a **Breakfast Briefing**
Free 3-hour seminar
Click Here to Sign Up!

Web Seminar
Learn the Basics of Online Assessment
>> Click Here <<

STAY CONNECTED

Questionmark Perception >>

Questionmark™ Perception™

Measure Knowledge, Skills and Attitudes Securely for Certification, Regulatory Compliance and successful Learning Outcomes

Manage the Entire Assessment Process

 The Questionmark™ Perception™ assessment management system enables trainers, educators and testing professionals to author, schedule, deliver, and report on surveys, quizzes, tests and exams.

Analyze and share results with stakeholders using 12 standard reports



Reporting

Authoring

Scheduling

Delivery

Questionmark Perception

SECURITY

Deliver via browser, secure browser, mobile devices or paper

Author questions and organize them into exams, quizzes, tests or surveys

Schedule assessments for participants and groups and email broadcast login details

Other Reporting: SAP ERP

SAP Easy Access

The image shows a screenshot of the SAP Easy Access navigation tree. The tree is organized into several levels of folders and reports. The top level includes 'Time Management', 'Payroll', and 'SAP Learning Solution'. Under 'SAP Learning Solution', there are folders for 'Participation', 'Courses', 'Resources', and 'Information System'. The 'Information System' folder is expanded to show a list of reports, including 'LSO_PSV3 - Information Menu', 'Reports', 'Participation', and 'Courses'. The 'Courses' folder is further expanded to show a list of 15 specific reports, each with a cube icon.

- ▶ Time Management
- ▶ Payroll
- ▼ SAP Learning Solution
 - ▶ Participation
 - ▶ Courses
 - ▶ Resources
 - ▼ Information System
 - LSO_PSV3 - Information Menu
 - ▼ Reports
 - ▶ Participation
 - ▼ Courses
 - LSO_RHXKBED0 - Course Demand
 - LSO_RHABLAUF_OLD - Course Schedule
 - LSO_RHXEVALV_OLD - Course Appraisals
 - LSO_RHXCGRP0 - Course Hierarchy
 - LSO_RH XKURS2 - Participation Statistics
 - LSO_RH XKBRO0 - Course Brochure
 - LSO_RHSEMI60 - Course Information
 - LSO_RH XKBRO1 - Course Dates
 - LSO_RHXERES0 - Resource List per Course
 - LSO_RHXORES1 - Resources Not Yet Assigned per Course
 - LSO_RHXMARP0 - Material Requirements per Course
 - LSO_RH XKBRO2 - Course Prices
 - LSO_TAC_TRAIN_RESULT - Course Results Overview
 - LSO_TAC_ITEMSTAT - Test Item Statistics

Other Reporting: BW

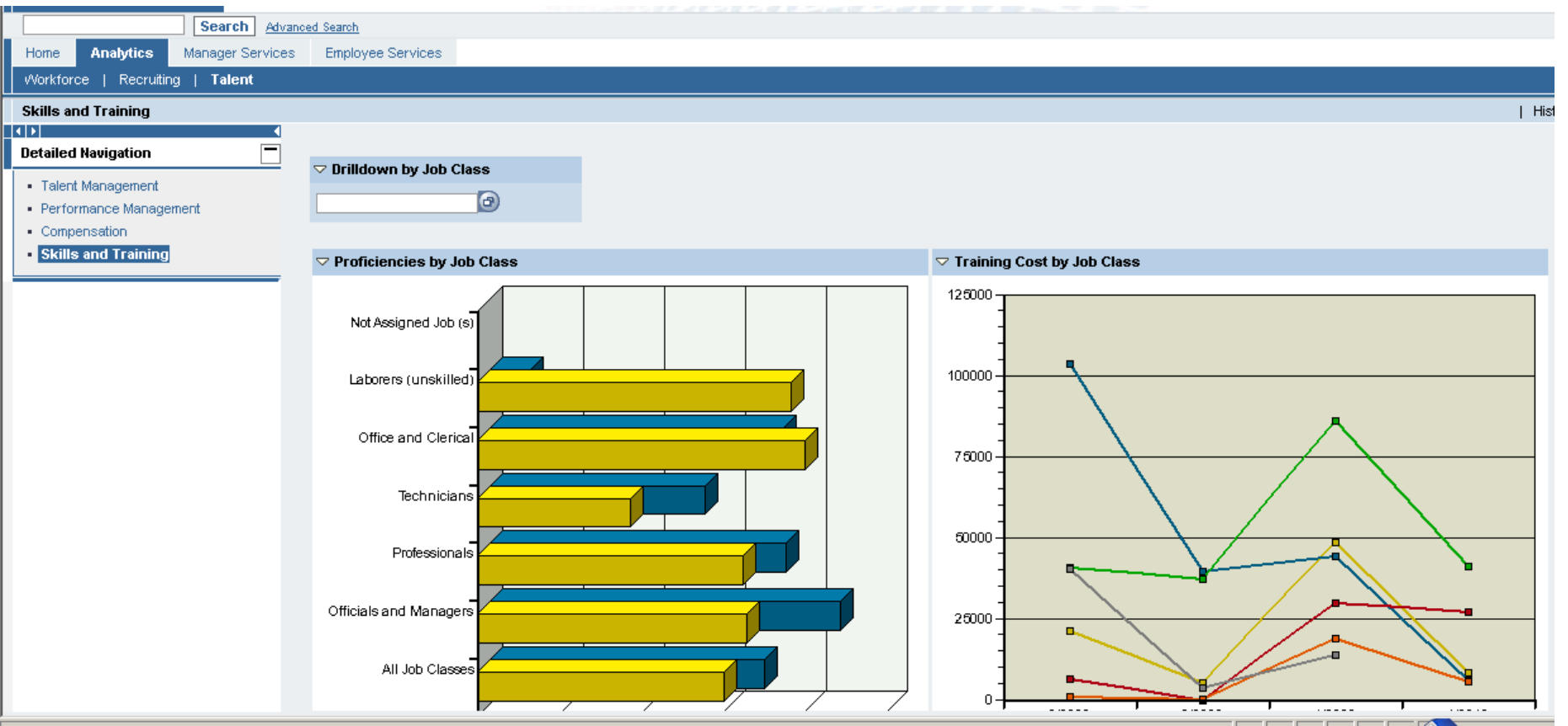

Content Creation

- Also we have tried outputs from various tools including articulate, Atlantic link etc. Do you have any standards/recommendations re creation and publication of content that you can provide us with?

http://www.rwd.com/solutions/learning_solutions.aspx



Best Practices



SAP LSO Content Partner

